

DO NOT
SCALE FROM
THIS PRINT

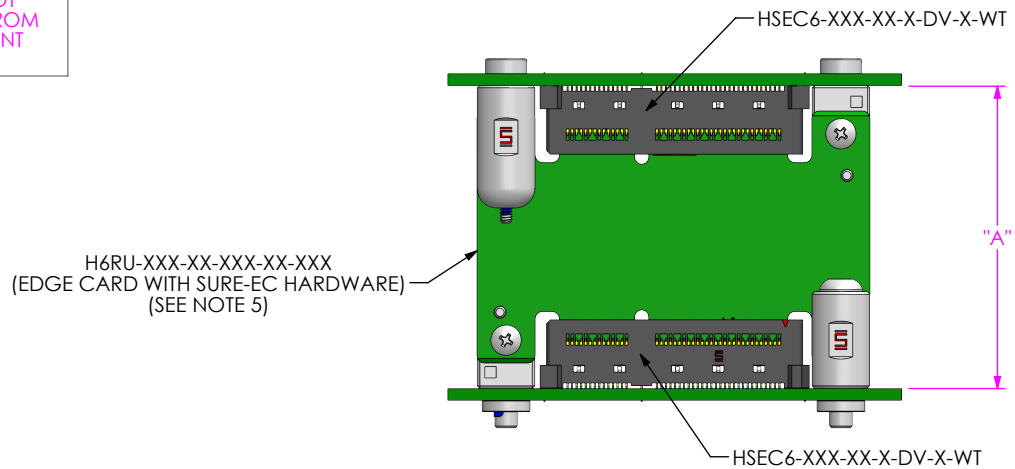

TABLE 1

STACK HEIGHT	"A"
-025	25.00 [0.984]
-030	30.00 [1.181]
-040	40.00 [1.575]
-050	50.00 [1.969]
-060	60.00 [2.362]

FIG 1
HSEC6 TO H6RU TO HSEC6 MATED VIEW

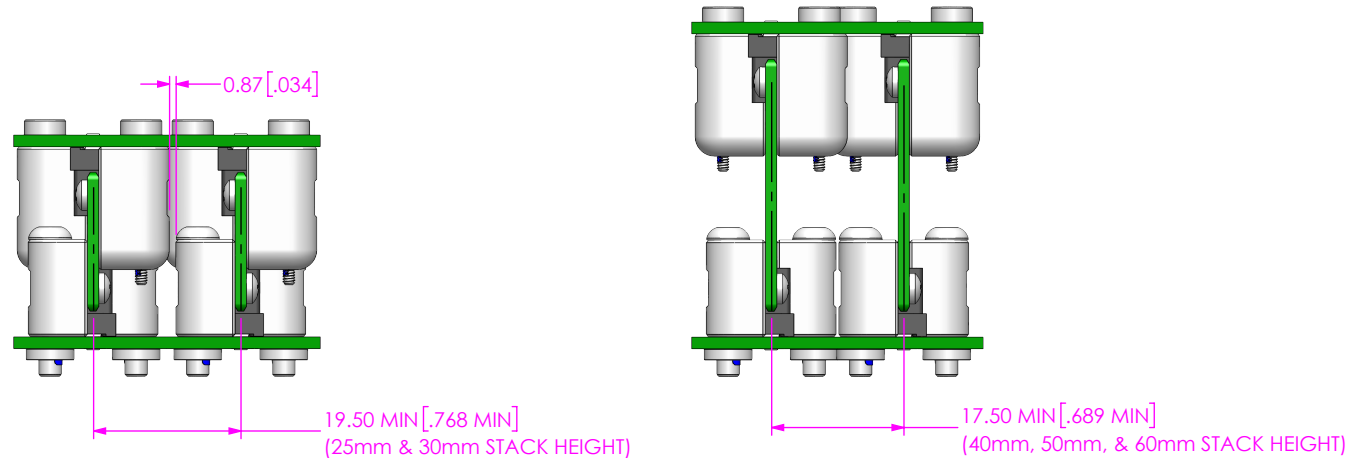
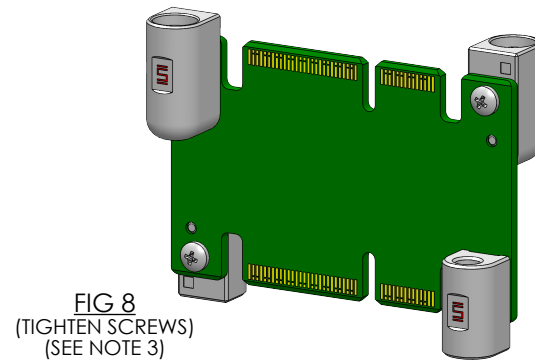
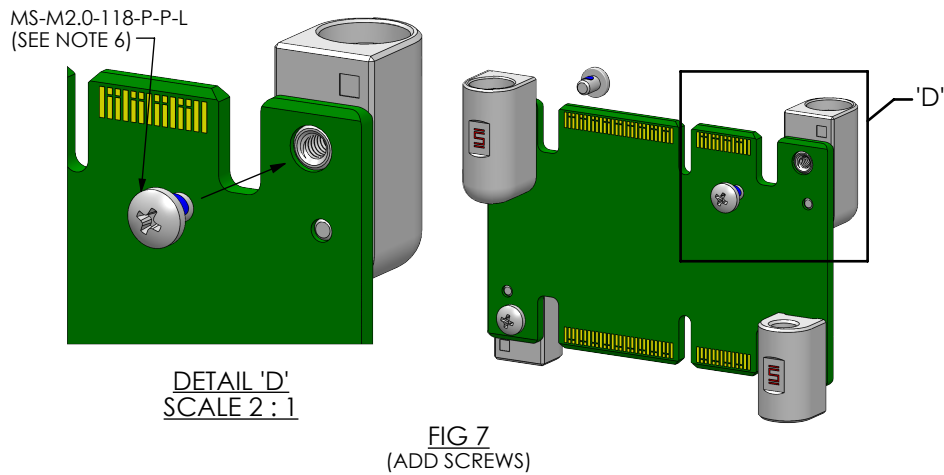
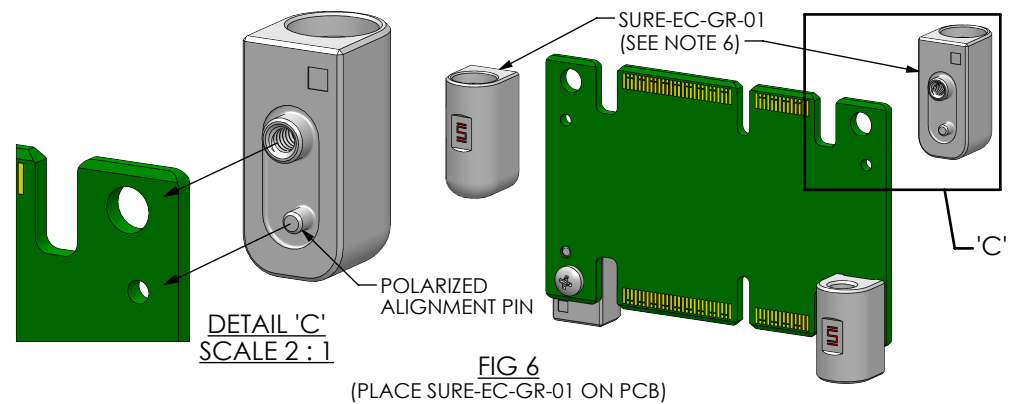
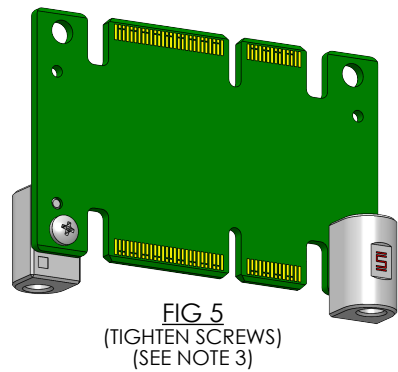
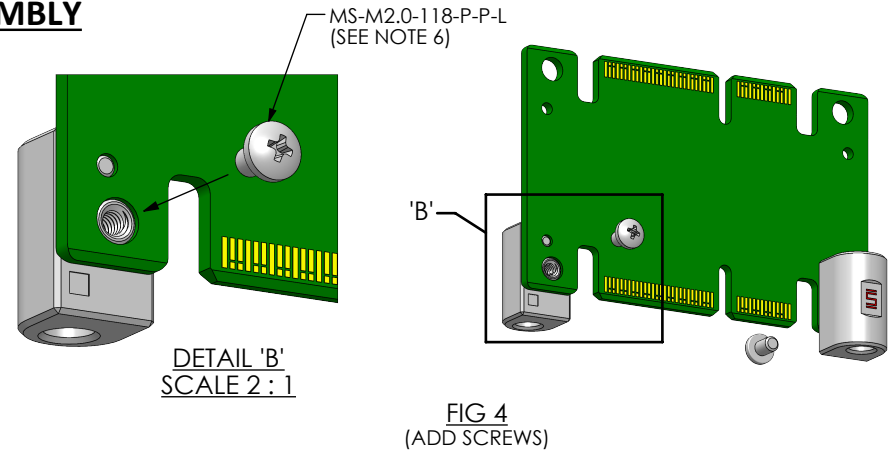
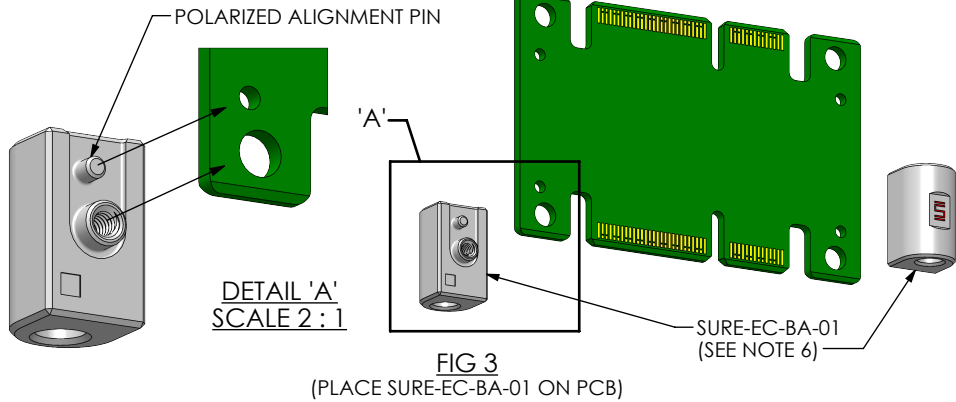

FIG 2
MINIMUM SPACING REQUIREMENTS

- NOTES:
1. TIGHTEN MS-M3.0-709-B-6H-L FASTENERS TO 5.567 IN-LBS (2 PLCS).
 2. TIGHTEN SURE-EC-GS-01 TO 0.76 IN-LBS (2 PLCS).
 3. TIGHTEN MS-M2.0-118-P-P-L FASTENERS TO 1.558 IN-LBS (4 PLCS).
 4. STANDARD HARDWARE IS DESIGN FOR 1.57[.062]-3.18[.125] PCB THICKNESS.
 5. SEE HSEC6-XXX-XX-X-DV-X-WT-XR-FOOTPRINT FOR CONNECTOR & HARDWARE PLACEMENT.
 6. SEE SURE-EC-XX FOR HARDWARE KIT DETAILS.

<p>PROPRIETARY NOTE</p> <p>THIS DOCUMENT CONTAINS CONFIDENTIAL AND PROPRIETARY INFORMATION AND ALL DESIGN, MANUFACTURING, REPRODUCTION, USE, PATENT RIGHTS AND SALES RIGHTS ARE EXPRESSLY RESERVED BY SAMTEC, INC. THIS DOCUMENT SHALL NOT BE DISCLOSED, IN WHOLE OR PART, TO ANY UNAUTHORIZED PERSON OR ENTITY NOR REPRODUCED, TRANSFERRED OR INCORPORATED IN ANY OTHER PROJECT IN ANY MANNER WITHOUT THE EXPRESS WRITTEN CONSENT OF SAMTEC, INC.</p>	 520 PARK EAST BLVD., NEW ALBANY, IN 47150 PHONE: 812-944-6733 FAX: 812-948-5047 e-Mail info@SAMTEC.com code 55322	
	DO NOT SCALE DRAWING SHEET SCALE: 1:1	DESCRIPTION: HSEC6 MATING CARD
BY: EVE L		2/22/2024 SHEET 1 OF 4

EDGE CARD ASSEMBLY



PROPRIETARY NOTE
 THIS DOCUMENT CONTAINS CONFIDENTIAL AND PROPRIETARY INFORMATION AND ALL DESIGN, MANUFACTURING, REPRODUCTION, USE, PATENT RIGHTS AND SALES RIGHTS ARE EXPRESSLY RESERVED BY SAMTEC, INC. THIS DOCUMENT SHALL NOT BE DISCLOSED, IN WHOLE OR PART, TO ANY UNAUTHORIZED PERSON OR ENTITY NOR REPRODUCED, TRANSFERRED OR INCORPORATED IN ANY OTHER PROJECT IN ANY MANNER WITHOUT THE EXPRESS WRITTEN CONSENT OF SAMTEC, INC.

DO NOT SCALE DRAWING
 SHEET SCALE: 1:1

samtec

520 PARK EAST BLVD., NEW ALBANY, IN 47150
 PHONE: 812-944-6733 FAX: 812-948-5047
 e-Mail: info@SAMTEC.com code 55322

DESCRIPTION:
 HSEC6 MATING CARD

DWG. NO.
H6RU SURE-EC APPLICATION

BY: EVE L 2/22/2024 SHEET 2 OF 4

TOP/BOTTOM BOARD ASSEMBLY

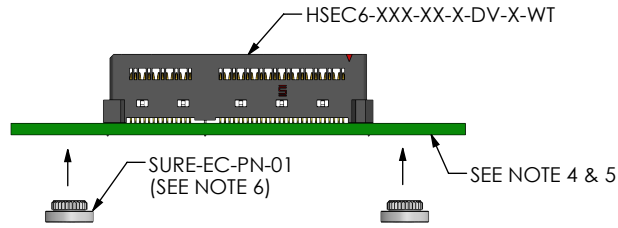

FIG 9
INSERT PRESS-IN NUT ON BOTTOM PCB

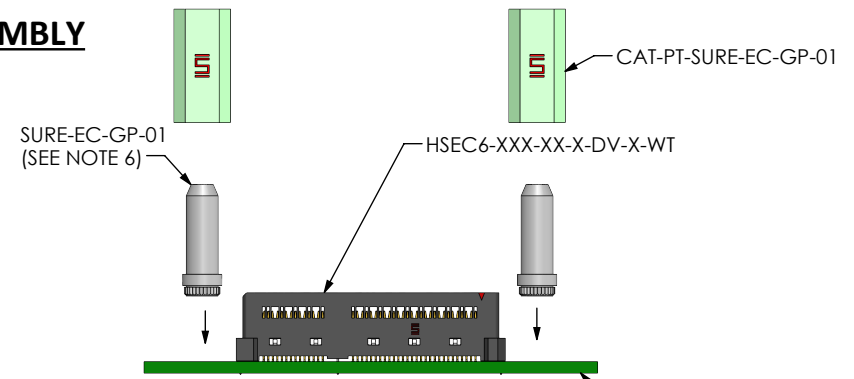

FIG 10
INSERT GUIDEPOST ON TOP PCB

HSEC6 TO H6RU TO HSEC6 ASSEMBLY

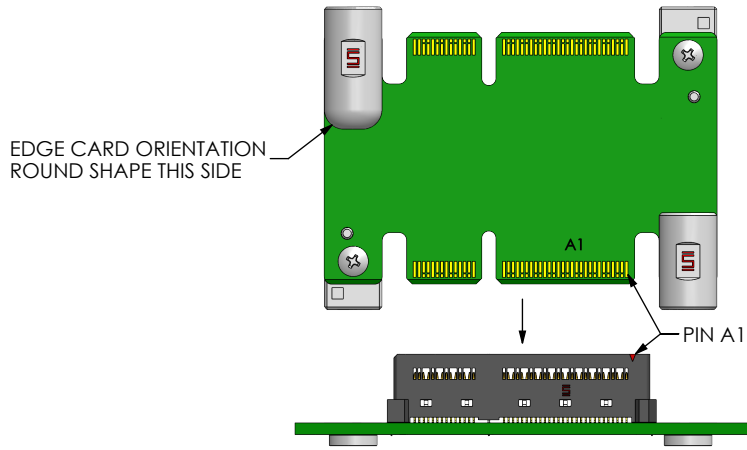

FIG 11
MATE EDGE CARD WITH HSEC6 CONNECTOR ON BOTTOM PCB

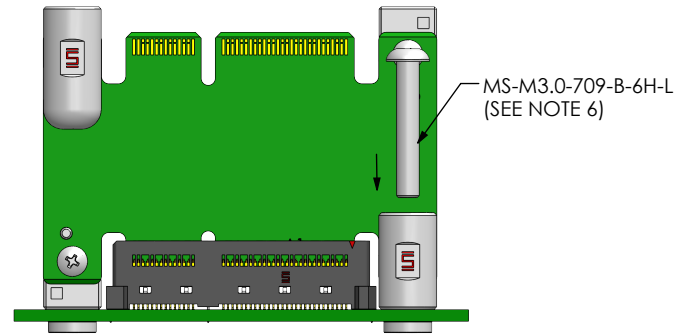

FIG 12
ADD SCREWS

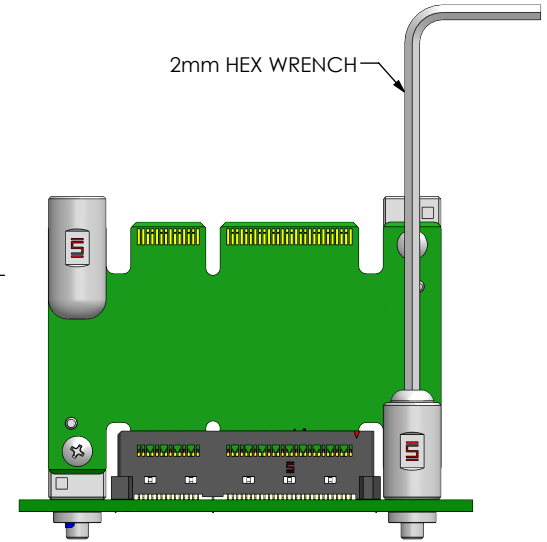

FIG 13
TIGHTEN SCREWS
(SEE NOTE 1)

PROPRIETARY NOTE
THIS DOCUMENT CONTAINS CONFIDENTIAL AND PROPRIETARY INFORMATION AND ALL DESIGN, MANUFACTURING, REPRODUCTION, USE, PATENT RIGHTS AND SALES RIGHTS ARE EXPRESSLY RESERVED BY SAMTEC, INC. THIS DOCUMENT SHALL NOT BE DISCLOSED, IN WHOLE OR PART, TO ANY UNAUTHORIZED PERSON OR ENTITY NOR REPRODUCED, TRANSFERRED OR INCORPORATED IN ANY OTHER PROJECT IN ANY MANNER WITHOUT THE EXPRESS WRITTEN CONSENT OF SAMTEC, INC.



520 PARK EAST BLVD, NEW ALBANY, IN 47150
PHONE: 812-944-6733 FAX: 812-948-5047
e-Mail: info@SAMTEC.com code 55322

DO NOT SCALE DRAWING
SHEET SCALE: 1:1

DESCRIPTION:
HSEC6 MATING CARD

DWG. NO.
H6RU SURE-EC APPLICATION

BY: EVE L 2/22/2024 SHEET 3 OF 4

HSEC6 TO H6RU TO HSEC6 ASSEMBLY

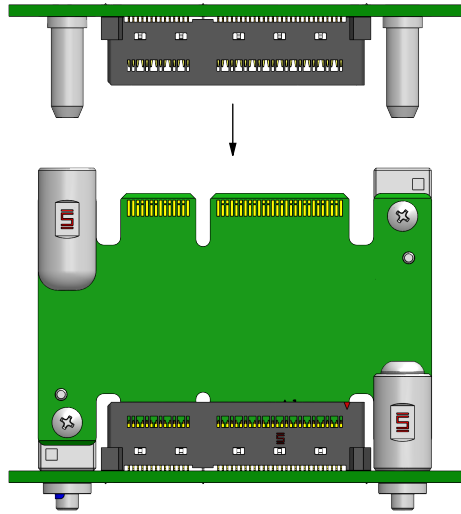

FIG 14
MATE HSEC6 CONNECTOR ON TOP PCB

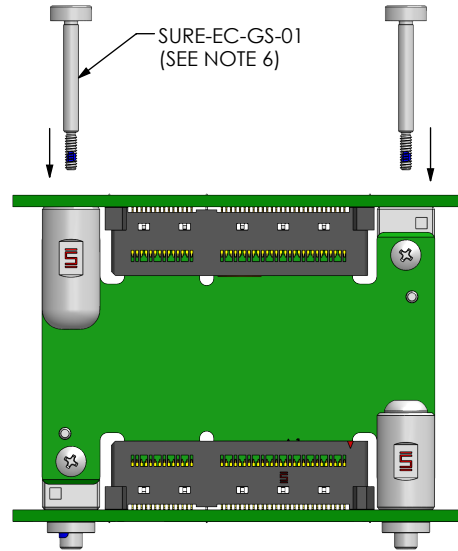

FIG 15
ADD GUIDPOST SCREWS

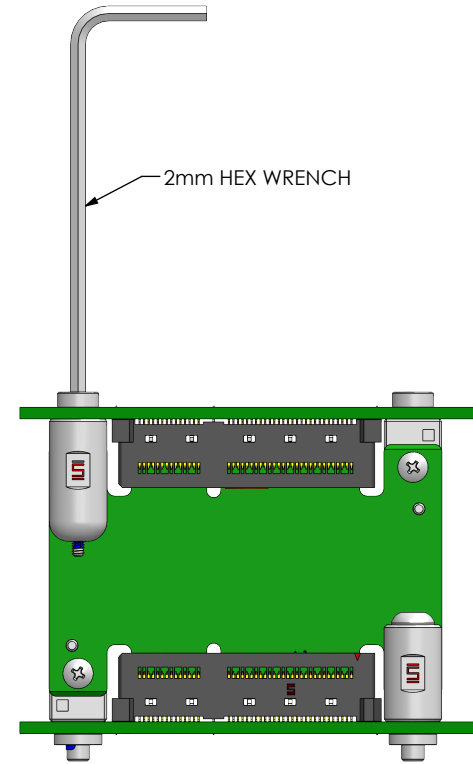

FIG 16
TIGHTEN GUIDPOST SCREWS
(SEE NOTE 2)

PROPRIETARY NOTE
 THIS DOCUMENT CONTAINS CONFIDENTIAL AND PROPRIETARY INFORMATION AND ALL DESIGN, MANUFACTURING, REPRODUCTION, USE, PATENT RIGHTS AND SALES RIGHTS ARE EXPRESSLY RESERVED BY SAMTEC, INC. THIS DOCUMENT SHALL NOT BE DISCLOSED, IN WHOLE OR PART, TO ANY UNAUTHORIZED PERSON OR ENTITY NOR REPRODUCED, TRANSFERRED OR INCORPORATED IN ANY OTHER PROJECT IN ANY MANNER WITHOUT THE EXPRESS WRITTEN CONSENT OF SAMTEC, INC.



520 PARK EAST BLVD, NEW ALBANY, IN 47150
 PHONE: 812-944-6733 FAX: 812-948-5047
 e-Mail: info@SAMTEC.com code 55322

DO NOT SCALE DRAWING
 SHEET SCALE: 1:1

DESCRIPTION:
 HSEC6 MATING CARD

DWG. NO.
 H6RU SURE-EC APPLICATION

BY: EVE L 2/22/2024 SHEET 4 OF 4